

"Research Note"

THEORETICAL AND ANALYTICAL INVESTIGATION OF LIGHTNING OVER-VOLTAGES AND ARRESTER OPERATION*

A. GHOLAMI**, M. MIRZAIE AND M. R. ASEBAN

College of Electrical Engineering, Iran University of Science & Technology (IUST), Tehran, I. R. of Iran
Email: Gholami@iust.ac.ir

Abstract– One of the main problems in high voltage networks is over voltages due to lightning. These over voltages, which are not possible to prevent, create problems where the insulating level of the equipment is not enough. Selecting a high insulating level will increase the costs and volume of the equipment. For the sake of decreasing insulating levels and their costs, it is necessary to control over voltages and lead them to earth by equipment like arresters.

In this paper, over voltages, mostly due to lightning and its dangers to power networks, have been studied for: 1- The effect of arrester earthing resistance, 2- Tower footing resistance, 3- Capacitive voltage transformer and 4- Tower structure. An EMPT program has been used for simulation of a line and a substation of 230kv/123kv (Ahwaz-Omidieh) as a case study.

Keywords – Lightning, over voltages, networks and arresters operation

1. INTRODUCTION

Lightning phenomena is defined as the transfer of collected electric charges in clouds to earth due to the electric arc. At a suitable distance from the substation, lightning on phase conductors and reverse arcs cause waves to spread in line length before the entrance to the substation. When the lightning takes place near the substations, the reversed waves, with considerable slope and amplitude, will destroy the insulation of different equipment in the network. Therefore, to prevent this problem, the rods are installed on the total length of string insulators on the end as well as on the second to last tower before the entrance to the substation. Also, to prevent the reverse arc and voltage waves from raising to substations, the grounding resistances around the substations are reduced considerably (often 2 or 3 towers at the end lines are connected to substation earthing system). Another way to prevent these waves from entering high voltage substations is to use arresters. These arresters can also be used to block outage of transmission lines, which cause reverse voltage phenomena [1, 2]. In this paper, we discuss lightning behaviour for producing over voltages, as well as important factors to over voltages. Their effects on the amounts of energy absorbed by arresters have been briefly analyzed.

2. ANALYSIS OF LIGHTNING OPERATION

The transmission lines are the most common part of networks affected by lightning phenomena. The lightning also affects the high voltage substation, but the range of this influence is much lower (4%), than the influence on transmission lines. This is because of the low area of the substation, considerable metallic structures and a low value of resistance. So the over voltages due to lightning on substations can be neglected.

*Received by the editors January 14, 2002; final revised form September 22, 2005.

**Corresponding author

There are many reasons for over voltages due to lightning. These include direct strikes on phase conductors and/or induced voltage due to the lightning on tower structures, ground wires, and reverse arc on transmission lines. This arc occurs when the difference of ground conductor voltage and induced voltage in phase conductors is greater than 50% of the string insulator. By considering the above points, lightning phenomena is the cause of a single-phase short circuit to ground and also voltage discharge from the string insulator to the tower structure. After short-circuiting, the protective systems operate, and by opening a circuit breaker, large customers will be removed from the system [3, 4]. In a transmission line has been simulated by spice soft ware [5].

3. SIMULATION OF LIGHTNING OVER VOLTAGES IN THE SYSTEM UNDER CONSIDERATION

The traveling waves are caused by lightning. If they are 3 to 5km from the substation they will vanish. The transmission lines and high voltage substations only a few kilometers from the substations are modeled, and for the remaining parts of the line, surge impedance can be used. Therefore, 132kV transmission lines of Ahwaz1-Omidieh have been selected for simulation with EMTP software and their characteristics are shown in the Table in the appendix. Also, the overall substation schematic is shown in Fig. 1. In the above simulation, points like the type of towers, phase & ground conductors and their height from ground surface, protective angle of ground wires, and the number of insulators have been taken into account and modeled. Also the real nonlinear resistive model for the ZnO surge arrester has been used. (This model and the simulated diagram are shown in the appendix.) Therefore, the system has been simulated with EMTP software. Moreover, in this model, spacer insulators of substation equipment are modeled with a capacitor and furthermore, capacitive effects of bushings and transformers have been taken into account [6].

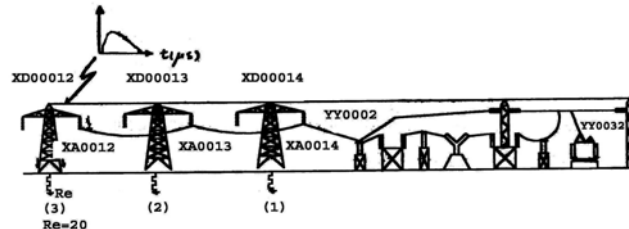

Fig. 1. View of dead end tower near 230kV/132kV Ahwaz1-Omidieh substation

Studying Fig. 1, it can be seen that a lightning wave is arising in Tower 3 with amplitude and resistance of 64kA and 20Ω respectively. By simulation, if the voltage points of XA0012, XA0013 and XA0014 are the same as in Fig. 2a, the lightning wave reaches to Towers 1 and 2, after striking to the Tower 3, causing reverse voltage phenomena to phase conductors in 1.8 and 2.8 μsec respectively. Additionally, the effects of tower ground resistance when the lightning wave arises to Tower 3 has been simulated and its result is indicated in Fig. 2b.

We know that energy absorbed by surge arresters produces large amounts of heat energy in a few milliseconds. Therefore, maximum accepted energy in surge arresters is an important problem.

In Fig. 3, energy absorbed by the surge arrester is shown, When lightning arises to Tower 3. Considering Fig. 3, we can see that the energy absorbed by a substation input surge arrester is equal to 16kJ. Therefore, 15.9kJ increased energy has been shown in consumption in the first step. These repeating discharges result in sever problems for the arrester disc.

By considering Fig. 3, when lightning arises to Tower 3, its current is transmitted to earth because of low tower resistance. This increased wave in Tower 3 (which is to reverse voltage phenomenon) moving to the sides of Towers 1 and 2, causes a reverse voltage from the phase to the Tower. As a result, this wave is transmitted to earth due low Towers resistance. On the other hand, the attained traveling wave

from Tower 3 to Tower 2 is transmitted to the earth as a guard conductor and this phenomenon produces a reverse voltage from phase to Tower 2. Therefore, the received wave to arrester has with low amplitude. (Point XA0014 that it has been shown in Fig. 1). Now, if earth's resistance of the tower increase, reverse voltage will occur from phase to Tower 1 and 2 under the condition of a greater amount of voltage and then the voltage amplitude received by the arrester increases its absorbed energy.

If lightning reaches Tower 1, voltage points, XA0014 and XA0015 are the same as shown in Fig. 4, considering tower ground resistance to 50Ω & 100Ω . Also Fig. 5 shows the amounts of energy absorbed by surge arresters in different states. Therefore, if the capability of absorbed energy is 350kJ by the surge arrester, then ten sequential discharges will result in the breaking of the surge arrester. In the second case, the absorbed energy of the surge arrester is equal to 90kJ . Now if the capability of absorbed energy of the surge arrester is 350kJ , four consecutive discharges in a sequence will result in the arrester breaking again.

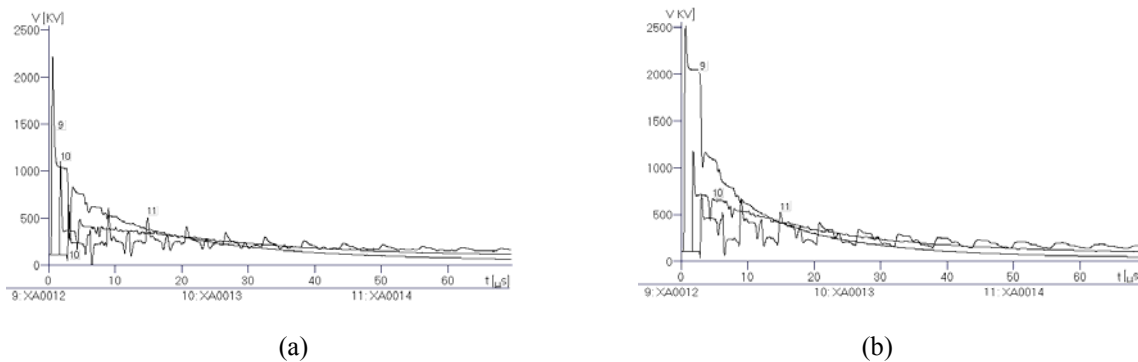

Fig. 2. Different voltage points corresponding to Fig.1, due to lightning arising to Tower 3
a) with tower resistance of 20Ω , b) with tower resistance of 50Ω

4. EVALUATION OF EFFECTIVE PARAMETERS ON AMOUNT OF LIGHTNING OVER VOLTAGES

The effects of different factors on lightning over voltages are described as follows:

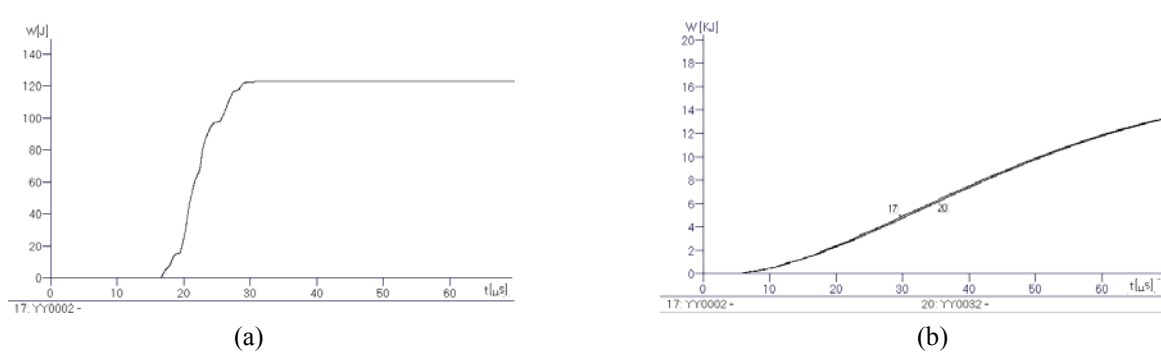

Fig. 3. Energy absorbed by arrester at the input of substation on YY0021 due to lightning arising on Tower 3, a) with tower resistance of 20Ω , b) with tower resistance of 50Ω

a) Arrester's grounding resistance

As mentioned above, when arrester-earthing resistances are 10Ω and 20Ω , the simulation has been performed and voltage drop has been calculated in the end sides of the substation arresters. Figure 6 shows voltage points YY0002 and YY0032. According to this Figure, with the increase of arrester earthing resistance, the arc increase occurred in the external or internal insulation surface of the equipment. According to Fig. 6b, lightning over voltage is due to its reflection in the point YY0032 being greater than the voltage in point YY0002.

b) Tower earth resistance

The effect of tower earthing resistance is shown in Fig. 2. Therefore, decreasing tower resistance causes the voltage drop on the tower and also the induced voltage in phases to decrease [7, 8].

c) Capacitive voltage transformer (CVT)

In this part, simulation has been done for Tower 3 with an earthing resistance of $20\ \Omega$ and lightning discharge amplitude of 34 kA. The results are shown in Fig. 7. The voltage wave of Fig. 7a is related to a substation when it does not have an arrester and CVT. When the substation has only CVT in the input, its voltage waveform will be as shown in Fig. 7b.

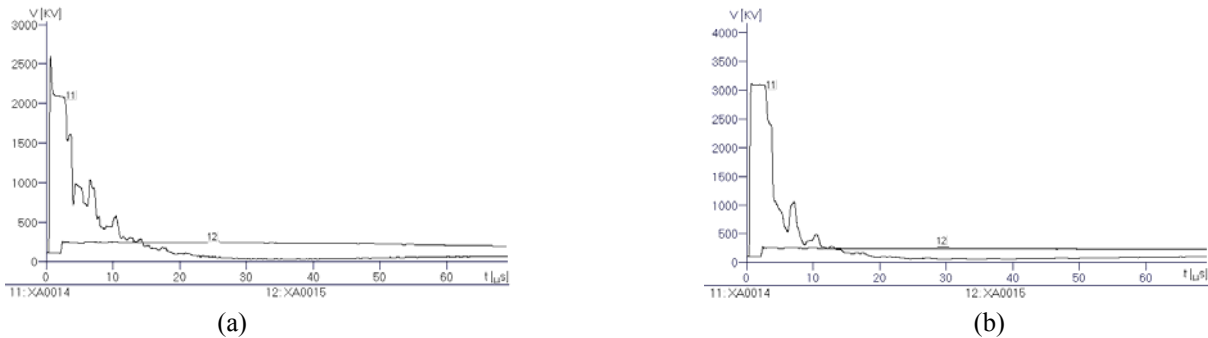

Fig. 4. a) Voltage of phase A in specified points due to lightning strike to Tower 1 a) with tower resistance of $50\ \Omega$, b) with tower resistance of $100\ \Omega$

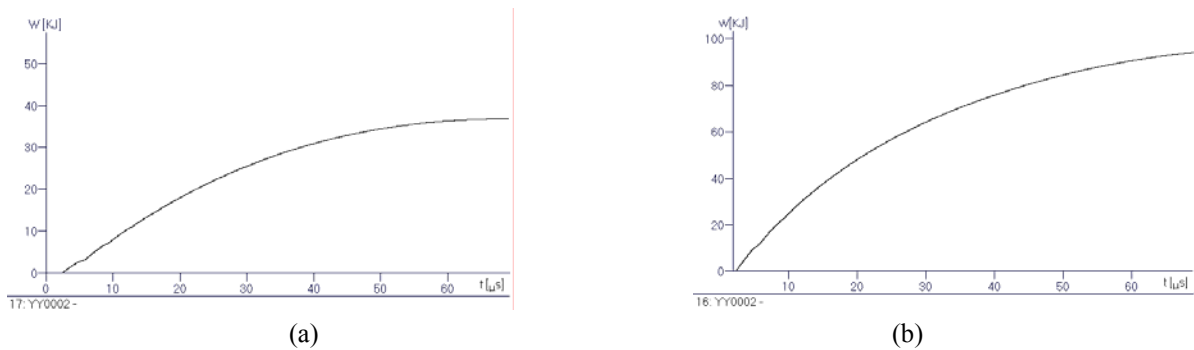

Fig. 5. a) Energy absorbed by the arrester due to lightning strike to Tower 1, a) with tower resistance of $50\ \Omega$ b) with tower resistance of $100\ \Omega$

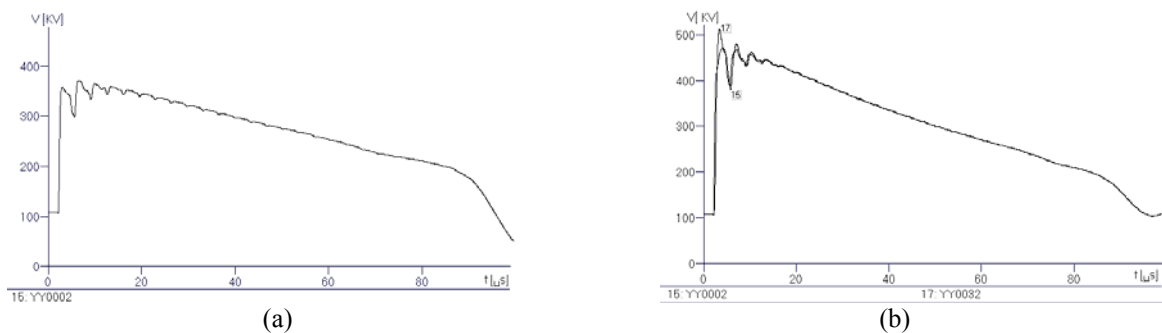

Fig. 6. a) Voltage of input arrester due to lightning arising with amplitude of 65 kA to node XD0014, a) with arrester earthing resistance of $10\ \Omega$, b) with arrester earthing resistance of $20\ \Omega$

By comparing these results, we observed that in CVT installing state, the voltage peak is decreased more than what was before. When the substation has no arresters, its input value goes up to 150 kV.

5. OPERATION EVALUATION FOR LINE SURGE ARRESTER AGAINST LIGHTNING OVER VOLTAGES

Lightning influence on a line surge arrester evaluated in the single circuit of 132kV Ahvaz1-Omidieh has been shown in Fig. 1. In simulation, the tower distance is 320m, while the substation end tower distance is 100m from it. Also, each line conductor is equipped with a line surge arrester and lightning waves that reach the top of Tower 3 (at the node XD0012) have an amplitude of 22.5kA. By considering the tower surge impedances and its ground resistance, the voltage amplitude at the top of the tower will reach 850kV.

Therefore, the line arrester is functioning according to the coordination between string insulator breakdown voltage and the arrester. Also, high amplitude tower voltage is transmitted to phase A. The results are shown in Fig. 8. A voltage wave occurred on phase A, and after traveling a distance of 320m, will reach the next tower. This voltage will be discharged to the tower by considering the surge arrester because of the increased voltage amplitude, in comparison with the arrester air gap, which withstands this voltage (Fig. 9).

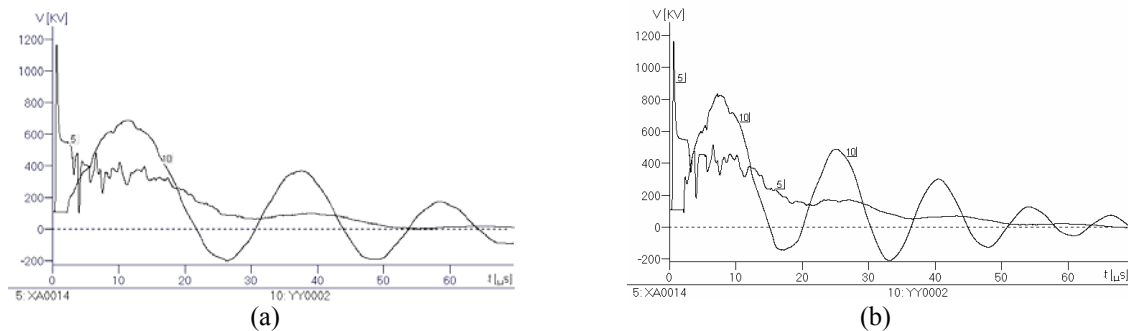

Fig. 7. a) Voltage waveform in input of substation due to lightning arising on Tower 3, a) with tower resistance of $20\ \Omega$ - when substation has not arrester and CVT), b) with tower resistance of $20\ \Omega$ - when substation has CVT and has not arrester)

The characteristics curve of the arrester discharge with negative amplitude is shown in Fig. 10. If the discharge current should be negative, then it shows that the discharge voltage direction is from phase to tower. The remaining voltage on the phase will be discharged to Tower 1 when it reaches the substation input tower; therefore the amplitude of the input wave to the substation as shown in Fig. 11, is lower than the equipment insulation level. Note that in this application the grounding resistance of each dead-end tower of 132kV substation should be less than $10\ \Omega$, so for the prevention of lightning over voltage waves to the substation, we can use line surge arresters [4, 6, and 9].

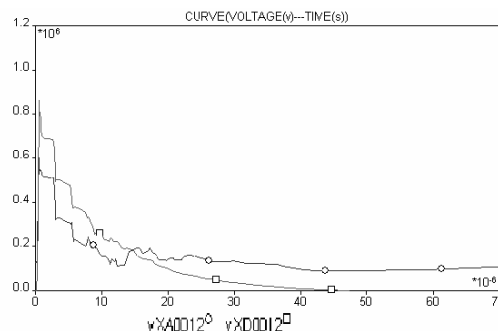

Fig. 8. Operation of the line arrester and transfer of over voltages to top of the tower to phase A (node XD0012) due to lightning (node XA0012)

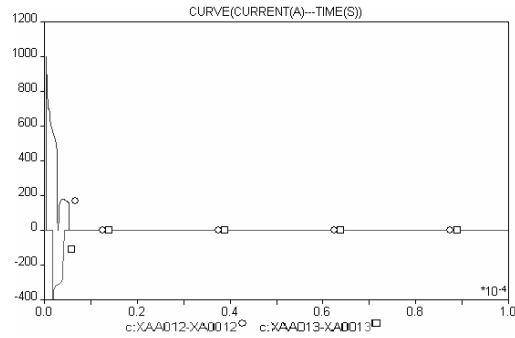

Fig. 9. Current discharge from Tower 3 to phase A, and also the lightning current discharge from phase A (at the node XD0013) to Tower 2 (by arrester)

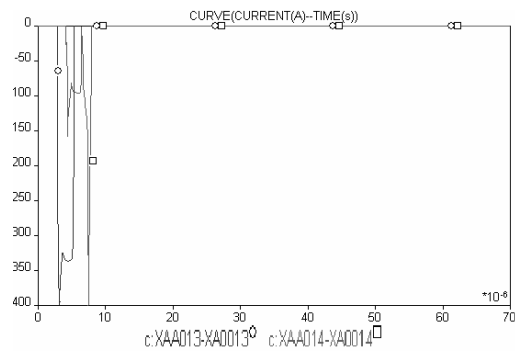

Fig. 10. Tower arrester discharge current in phase A (at the nodes XA0013 and XA0014) due to striking of lightning to Tower 1, and arrester discharge from tower to phase A (at the node XD0012)

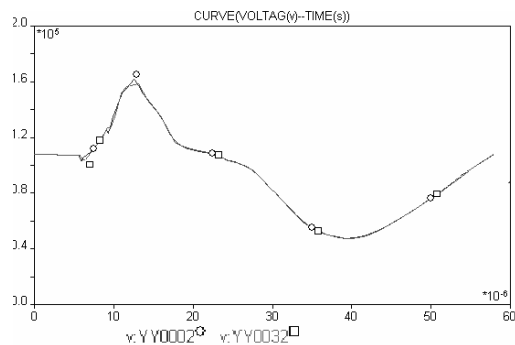

Fig. 11. Voltage dropped at the substation arresters due to striking of lightning to substation's dead-end tower after the operation of the line arrester

6. CONCLUSIONS

In this research, the effect of lightning over voltages on lines and substations, and also the energy absorbed by arresters have been simulated by using the information of the Ahvaz-Omidieh line and substation. According to this work, decreasing the end towers ground resistance to less than 10Ω is effective in decreasing the input traveling wave amplitude.

Also, if the distance between the input arrester and the substation transformer is high, then arrester installing in input to the transformer is required. Furthermore, CVT installing has an important role in decreasing the input voltage amplitude of the substation.

Moreover, decreasing of the arrester ground resistance can cause a decrease in the arrester circuit resistance. So, in the performed research, the following points are concluded:

- ▶ The ground of the end towers to the substation (a few towers near substation) should be connected to the substation earthing or tower resistance should approach less than $10\ \Omega$. (With lower surge impedances.)
- ▶ If possible, installing extra equipment in the path of earthing conductors should be avoided. The shortest way should be selected between the arrester and the point of its earthing wire. If possible it is recommended to use a CVT in the substation input and the connections should be visited periodically.
- ▶ The presence of a line arrester and the reduction of grounding resistance for a few end towers from the substation has a considerable influence on the reduction of lightning over voltage amplitude on the substation input. This prevents the possible outage of the transmission line.

REFERENCES

1. Wakai, T., Itamoto, N., Sakai, T. & Ishii, M. (2000). Evaluation of transmission line arrester against winter lightning. *IEEE Transaction on Power Delivery*, 15(2), 684-690.
2. Babuder, M., Kenda, M., Kotar, P., Brocard, E., Tartier, S., Joulie, R. & Sadovic, S. (1999). Lightning performance improvement of 123kV transmission line by use of line surge arresters. *11th International symposium on high voltage Engineering (ISH99)*, (CP467), p.v2-250, London, UK.
3. Kadomskaja, K. P. & Reicherdt, A. A. (1999). A study of operating conditions of lightning arresters installed on overhead line towers. *High Voltage Engineering Symposium, 11th International symposium on* (Conf. Publ. No. 467), Volume 2, 337-340, Meeting Date: 09/23/1999-08/27/1999, Novosibirsk State Tech. Univ. London, UK.
4. Kastrup, O., Zanetta L. C., Nigri, A., Campones doBrasil, D. O., Maldonado, P. & Moreira, F. A. (1998). Lightning performance assessment with line arresters. *Transmission and Distribution Conference, IEEE*, Los Angeles, CA, USA, 288-293.
5. Kraft, L. A. (1991). Modeling lightning performance of transmission systems using PSpice. *PowerSystem Transactions, IEEE*, 6(2), Valparaiso Univ., IN, 543-549.
6. Furukawa, S., Usuda, O., Isozaki, T. & Irie, T. (1989). Developing and application of lightning arresters for transmission lines. *IEEE on Power Delivery Transactions*, 4(4), 2121-2129.
7. Koch, R. E., Timoshenko, J. A., Anderson, J. G. & Shih, C. H. (1985). Design of zinc oxide transmission arresters for application on 138 kV tower. *IEEE Transaction on Power Apparatus and Systems, PAS-104*(10), 2675-2680.
8. Bialek, T. (1985). Insulation system protection with zinc oxide surge arresters. *Electrical Insulation Magazine, IEEE*, 15(1), Pacific Gas & Elec. Co., San Ramon, CA, 5-10.
9. Aseban, R. & Gholami, A. (1999). Analyzing factors in destruction of arresters and presenting solutions in decreasing of these factors. *M.S. Thesis, Iran University of Science and Technology*.

APPENDIX

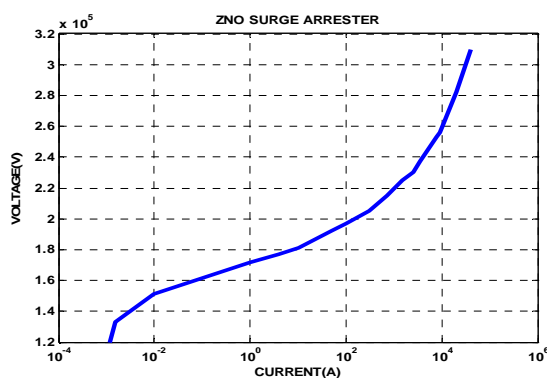

Fig. 1. ZNO surge arrester nonlinear characteristics

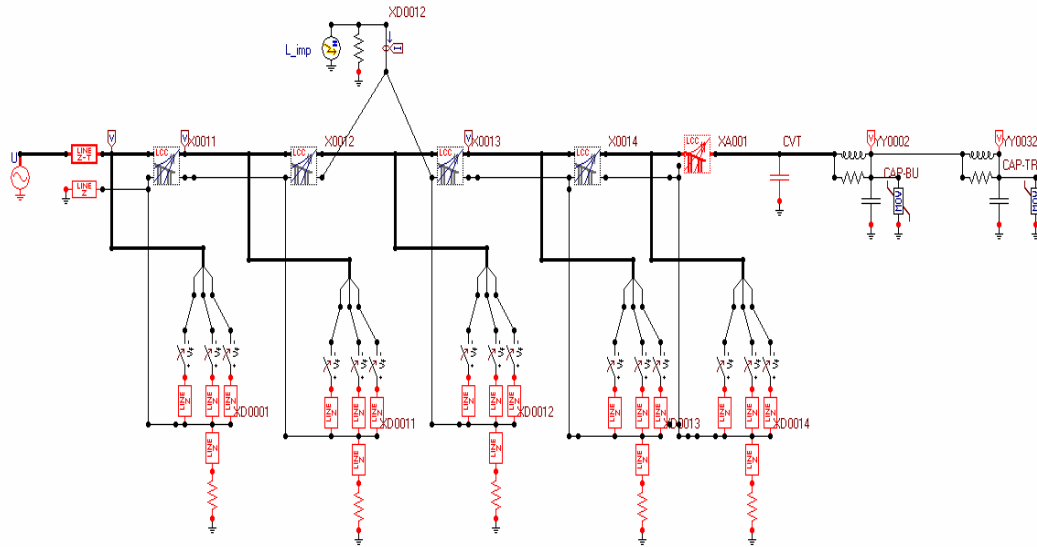

Fig. II. Diagram of simulated model on EMTP

Table. Characteristics of studied network

Transmission line and transformer parameters	Ahwaz1-Omidieh line and substation
Level of area isochrones	15
Numbers of insulators in insulator string	12(254×146)
Type of phase conductors	DRAKE
Phase conductor diameter (mm)	28.14
Name of guard wire	4 No.6
Guard wire diameter (mm)	8.35
Effective height of guard wire (m)	28
Effective height of phase conductor (m)	24
Type of tower	steel
Distance of line studied (km)	3
Insulating level of equipment (kv)	650
Transformer's power (MVA)	50
Capacitive property of transformer (PF)	5000
C.V.T capacitive property (PF)	7500
Input Bushings capacitive property (PF)	250
Distance between two towers (m)	350
Line protective angle (degree)	15
Tower model	Series resistance with inductor R= 20 Ω, L=1.2 μH/m
Phase conductor resistive (Ω/km)	0.0714
Ground conductor resistance (Ω/km)	2.18
Line model	Semlyen