

SURGE SUPPRESSION USING A FUZZY HYSTERESIS-BAND CONTROLLED RESISTOR ARRAY*

K. POURHOSSEINI¹ AND MOHAMMAD S. NADERI^{2**}

¹Islamic Azad University-Tabriz Branch, Tabriz, I. R. of Iran

²Imam Khomeini International University, Qazvin, I. R. of Iran

Email: salaynaderi@hotmail.com

Abstract– Transient over voltage protection has always been an important part of the electrical design of power systems. Metal–oxide varistor (MOV) has been a useful tool to limit the impulse voltage stress in recent years. This device has some disadvantages: 1. Its protection voltage is selected a little higher than the system nominal voltage. The main reason is the variation of the power frequency peak voltage, 2. It is only a two-valued resistor (switches between high and low impedances), 3. MOV has a relatively large slope resistance in conduction mode, 4. MOV’s protection process depends only on the voltage amplitude and has no obvious dependence on the variation rate of the voltage amplitude, 5. Threshold voltage of a MOV is a constant value and depends on its physical parameters. This paper presents a method to alleviate the aforementioned disadvantages and introduces a resistor array controlled by a fuzzy hysteresis-band controller to achieve a variable resistor. The first disadvantage is addressed using a power frequency voltage amplitude detector. Appropriate values of resistors and a switching strategy to parallel suitable resistors in the resistor array can lead to diverse values of the needed resistor. In this method load voltage derivative is utilized to help surge suppression and the threshold voltage has an adaptive variance due to power frequency voltage amplitude. It is also shown that the proposed circuit has negligible leakage current.

Keywords– Surge suppressor, fuzzy control, hysteresis-band control

1. INTRODUCTION

Transient over voltages can pose stresses against the power system insulation. These over voltages can lead to operational upset or product failure in industrial and commercial equipment and systems. This study introduces surge suppressors to protect the equipment and circuits from over voltages caused by lightning, switching transients, capacitor energizing, re-strike during capacitor de-energizing, line or cable energizing, current chopping and so on. Nearly all surge suppressors operate based on the voltage divider principle [1, 2]. They can be divided into two categories; blocking devices and shunting devices:

- 1) A blocking device detects excessive current flow, and increases its resistance sharply to hold the load current below some limits.
- 2) A shunting device detects excessive voltage and switches to a low impedance state so that the excess current goes through it, and not through the load.

A large number of surge suppressors in power systems are of shunting type. The ideal shunt transient suppression device would be an open circuit at normal voltages, would conduct without delay at some slight voltage above normal, would not allow the voltage to increase during the clamping period (Fig.1),

*Received by the editors April 6, 2008; Accepted April 16, 2009.

**Corresponding author

would handle unlimited currents and power, would revert back to an open circuit when the stress has gone, and would never wear out. But unfortunately, to date, there is no single transient suppression device that meets the ideal for all stress conditions specified in the standards. In Fig. 1 vertical axis is voltage amplitude in per unit (pu)

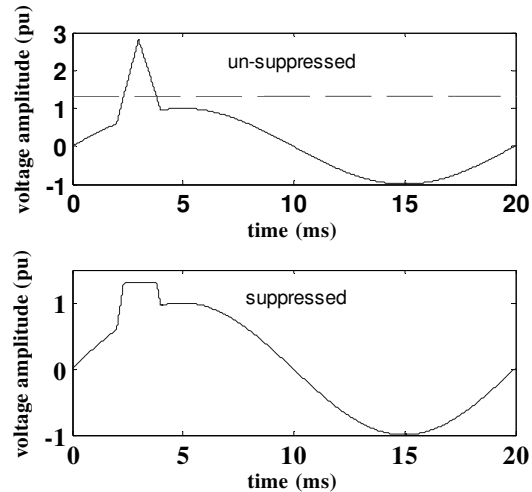

Fig. 1. Voltage suppression using an ideal suppressor (Reference voltage is constant)

Metal Oxide Varistor (MOV) is one of the most famous surge suppressors [3]. As the name implies, Metal Oxide Varistor (MOV) displays a voltage-dependent resistance characteristic. At voltages below the turnover (threshold) voltage these devices have high resistance. When the transient voltage exceeds the turnover voltage, the resistance decreases rapidly, and increasingly current flows in the shunt-connected varistor. For applications requiring high power dissipation, several columns of metal-oxide discs are connected in parallel inside the same porcelain housing [4]. The nonlinear V-I characteristic (Fig.2) of each column of the surge arrester is modeled by a combination of three exponential functions of the form:

$$\frac{V}{V_r} = k_i \left(\frac{I}{I_r} \right)^{1/\alpha_i} \quad (1)$$

in which: V_r is reference voltage, I_r is reference current and k_i and α_i are default parameters that fit the average V-I characteristic provided by the main metal-oxide arrester manufacturers and do not change with the protection voltage.

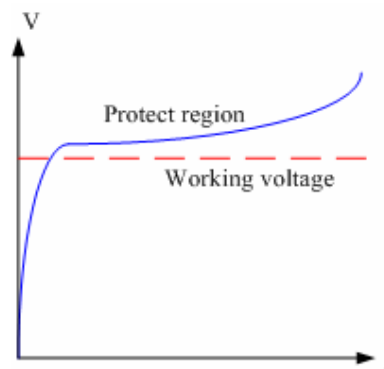

Fig. 2. V-I characteristic of MOV

The major advantage of the varistor is its low cost and relatively high transient energy absorption capability [2]. The major disadvantages are listed below:

- 1) Its protection voltage is selected a little higher than the system nominal voltage due to the variations in the peak power frequency voltage,
- 2) It is only a two-valued resistor (switches between high and low impedances),
- 3) MOV has relatively large slope resistance in conduction mode,
- 4) MOV's protection process depends only on the voltage amplitude and has no obvious dependence on the variation rate of the voltage amplitude,
- 5) Threshold voltage in a MOV is a constant value and depends on its design parameters, and
- 6) It has leakage current.

Utilizing fuzzy controlled resistor array can be of help to alleviate these disadvantages at some stages. In the proposed method, a programmable resistor is used which has a value that can be determined due to the system condition. An acceptable performance can be achieved by using an appropriate control algorithm. The present study introduces a novel circuit, then formulates the problem and reviews some basic concepts of fuzzy and hysteresis-band control method to reach the final stage, which is the simulation results and their interpretation.

2. PROPOSED CIRCUIT

A shunting device detects excessive voltage, and switches to a low impedance state so that the extra current passes through it, and not through the load. Shunting devices are much easier to design and build. The challenge is:

- 1) Maintaining low leakage current until reaching the threshold voltage,
- 2) Controlling the threshold voltage,
- 3) Maintaining low impedance after reaching the threshold voltage,
- 4) Returning to a low-leakage state when the transient or surge is over, and
- 5) Not destroying or degrading the device in the process.

Figure 3 shows a shunting suppressor parallel to the load. Conventional suppressors (MOVs) are nonlinear resistors (part A). These resistors' characteristics are nonlinear and time-invariant; in other words we do not have any control over its characteristic curve. Part B shows the proposed resistor array. This array consists of several resistors and can attain different values using an appropriate switching and control method.

3. PROBLEM DESCRIPTION AND FORMULATION

Nearly all transient voltage suppressors operate based on the voltage divider principle. Figure 4 represents a simplified circuit consisting of the power source side Thevenin equivalent circuit, surge source, transmission line in two sections, load and shunt suppressor. Equations (2-5) represent transmission line sending and receiving ends' relations [5, 6]. These relations are used to formulate the effect of surge suppressor impedance on load voltage and to calculate the line impedance between any two points. The aim is to calculate the surge effect on load voltage, so the impedance of the second section of the transmission line (between surge source and load) is determined. S is for the sending side (surge side) and R is for the receiving side (load side). It can be written:

$$V_S = V_R \cosh(\gamma) + I_R Z_C \sinh(\gamma) \quad (2)$$

$$I_s = I_R \text{Cosh}(\gamma l) + \frac{V_R}{Z_C} \text{Sinh}(\gamma l) \tag{3}$$

$$\gamma = \sqrt{yz} \tag{4}$$

$$Z_C = \sqrt{\frac{z}{y}} \tag{5}$$

in which:

- z : Series impedance per km
- y : Shunt admittance per km
- γ : Propagation constant
- Z_C : Characteristic impedance
- I_R : Receiving-side current
- V_S : Sending-side voltage
- V_R : Receiving-side voltage
- I_S : Sending-side current
- l : Distance between load bus and surge occurrence location on transmission line

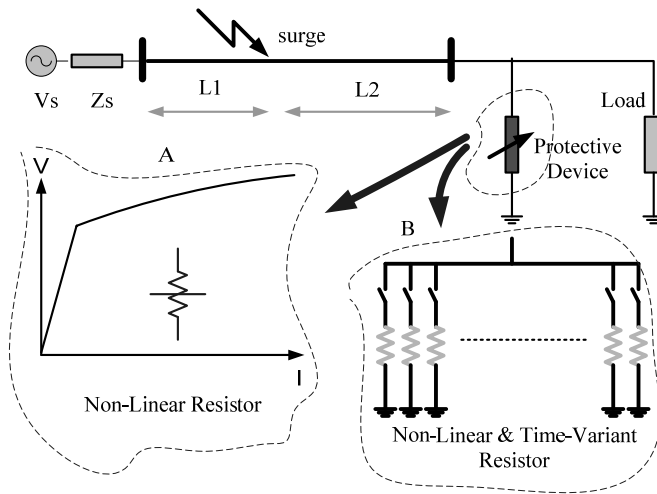

Fig. 3. Shunting suppressor (MOV vs. proposed method)

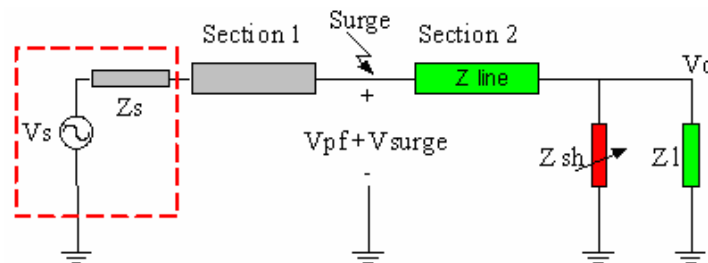

Fig. 4. Simplified circuit of simulated power system

V_{pf} is power frequency voltage in Fig. 4. Line equivalent impedance (Z_{line}) can be worked out using Eqs. (2-5). Output voltage (load) is:

$$V_o = V_o(pf) + V_o(surge) \quad (6)$$

$$V_o(surge) = \frac{(Z_l \parallel Z_{sh})}{(Z_l \parallel Z_{sh}) + Z_{line}} V_{in}(surge) \quad (7)$$

If Z_{sh} is pure resistance Eq. (7) can be rewritten as:

$$V_o(surge) = \frac{(Z_l \parallel R_{sh})}{(Z_l \parallel R_{sh}) + Z_{line}} V_{in}(surge) \quad (8)$$

Equation (8) shows that the surge effect can be mitigated using variable resistor R_{sh} .

4. DETECTION OF POWER FREQUENCY VOLTAGE (REFERENCE DETECTION)

In the proposed method, power frequency voltage (50 Hz) is the reference voltage to generate the error voltage, while in MOV, the reference voltage or threshold voltage is a constant value. This reference selection can lead to a better surge suppression and power factor improvement than MOV. A number of methods exist for determining the power frequency content of the sensed voltage waveform. Two common methods are band-pass filtering of the fundamental frequency component and instantaneous reactive power theory. Less common methods include the synchronous reference frame and fast fourier transforms (FFTs).

Band-pass filtering- This method detects the fundamental frequency component while leaving the remaining components. A single band-pass filter with a bandwidth of a few Hz has good isolating characteristics. The filter can significantly reduce the output THD.

Figure 5 shows sinusoidal reference voltage (solid-line) and over voltage suppression direction in positive and negative half-cycles (dash-lines and arrows).

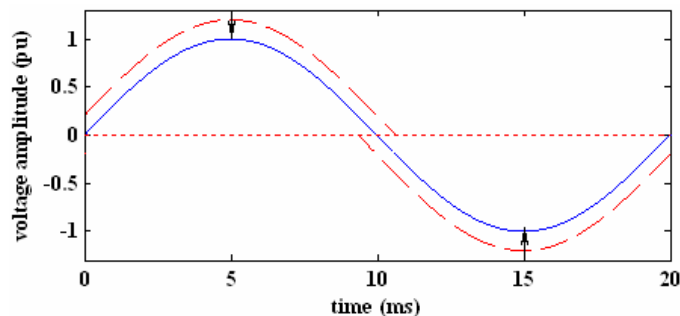

Fig. 5. a) Sinusoidal reference voltage (solid-line) b) Over voltage suppression direction in positive and negative half-cycles (dash-lines and arrows)

5. FUZZY CONTROL

a) Fundamentals of fuzzy logic control

Fuzzy logic control is a new addition to control theory. Its design philosophy deviates from all the previous methods by accommodating expert knowledge in a controller design. Fuzzy logic control is derived from fuzzy set theory introduced by Zadeh in 1965 [7]. Fuzzy Logic Controller (FLC) is an attractive choice when precise mathematical formulation is not possible. Other advantages of FLC are [7]:

- 1) It can work with less precise inputs,
- 2) It doesn't need fast processors,
- 3) It needs less data storage in the form of membership functions and rules than the conventional look-up table for non-linear controllers,
- 4) It is more robust than other non-linear controllers.

A reference input is compared with the bus voltage to be protected and produce an error. The error and its derivative are fed to the FLC, which performs calculations to generate the output.

b) Application of fuzzy logic control

Among the various available nonlinear controllers, the fuzzy logic controller, which is used to design controllers with complex dynamics, has been tested on many power electronic systems [7]. In the application presented in this study, the fuzzy control algorithm is designed to control the number of shunt resistors to be switched on to suppress the transient over voltages. The input variables are:

$$E = \pm(V_{out} - V_{ref})$$

+ in positive half cycle
- in negative half cycle

(9)

$$DE(t) = \frac{d}{dt} E(t)$$
(10)

A fuzzy controller consists of four stages: fuzzification, knowledge base, inference mechanisms, and defuzzification. The knowledge base is composed of a data base and rule base, and is designed to obtain good dynamic response under uncertainty in process parameters and external disturbances. The data base, consisting of input and output membership functions, provides information for the appropriate fuzzification operations, the inference mechanism, and defuzzification. The inference mechanism uses a collection of linguistic rules to convert the input conditions into a fuzzified output. Finally, defuzzification is used to convert the fuzzy outputs into control signals.

Determination of the membership functions depends on the designer's experience and expert knowledge. It is not easy to choose a particular shape that is better than the others. A triangular membership function has the advantages of simplicity and easy implementation, and is adopted in this application. Fig. 6 and Table 1 show the membership functions of the input and output linguistic variables and their description.

In the design of a fuzzy control system, the formulation of its rule set plays a key role in improvement of the system performance. The rule table contains 49 rules as shown in Table 2. Various inference mechanisms have been developed to defuzzify the fuzzy rules. In this study, max-min inference method is applied to get an implied fuzzy set of turning rules. The imprecise fuzzy control action generated by the inference engine must be transformed into a precise control action in a real application. Centroid method is used to defuzzify the implied fuzzy control variables.

Fuzzy logic is an heuristic logic, i.e. selection of rule-base depends on knowledge of the expert user. However, rule-base could be optimized using other optimization methods like genetic algorithms, particle swarm optimization and so on.

For example, in the above mentioned case; if DE is PM, E is ZE and output is less than L (for example M) then the system response will be slow and output voltage exceeds the upper allowed limit.

On the other hand, if DE is PM, E is ZE and output is larger than L (VL) then the system has rough behavior and output voltage has large oscillations.

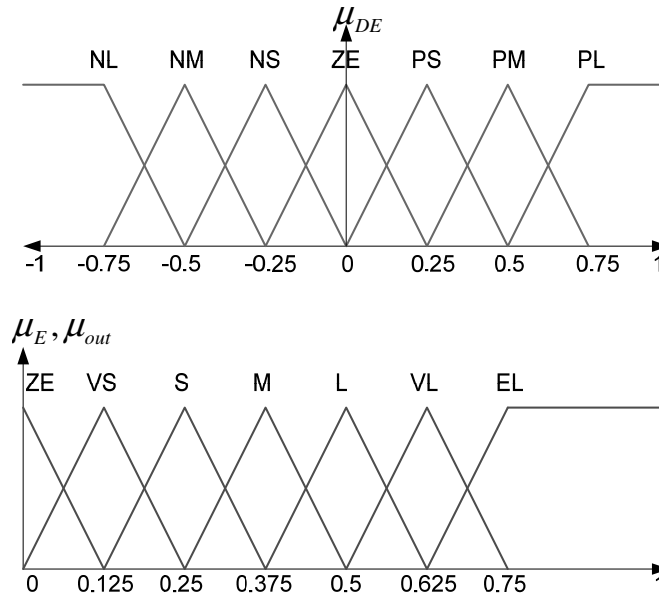

Fig. 6. Membership functions of the input and output linguistic variables (μ_{out} belongs to FLC output)

Table 1. Membership functions description

ES	Extreme small	NL	Negative large
VS	Very small	NM	Negative medium
S	Small	NS	Negative small
M	Medium	ZE	Zero equal
L	Large	PS	Positive small
VL	Very large	PM	Positive medium
EL	Extreme large	PL	Positive large

Table 2. Rule table
DE

	NL	NM	NS	ZE	PS	PM	PL
ZE	ZE	ZE	VS	S	M	L	VL
VS	ZE	VS	S	M	L	VL	EL
S	VS	S	M	L	VL	EL	EL
M	S	M	L	VL	EL	EL	EL
L	M	L	VL	EL	EL	EL	EL
VL	L	VL	EL	EL	EL	EL	EL
EL	VL	EL	EL	EL	EL	EL	EL

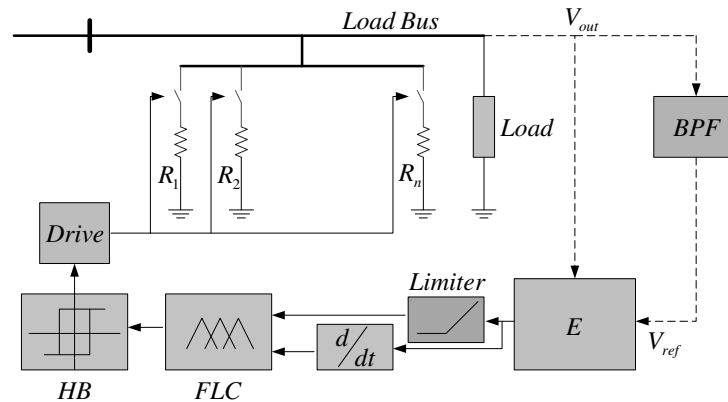

Fig. 7. Proposed circuit and control system

6. FUZZY HYSTERESIS BAND CONTROL

The most commonly used control strategies are the hysteresis control, the ramp comparison control methods associated with linear controllers, and the predicted control. The first method is very simple and easy to implement (Fig. 7). In this case, the operating conditions must be known to achieve sufficient and accurate control [8-10]. Consequently, a fuzzy hysteresis band circuit control for a sinusoidal input is applied in our application.

Blocks of E, Limiter, derivative, FLC, and HB are coded in a fast processor. All of the code could be implemented in a few bytes. Synchronization of V_{out} and V_{ref} is done in a processor using a proper time-delay.

Control block acts in order to reduce output over voltages to zero point. Due to the stochastic nature of the power system, controllers have to drive power switches to compensate these over voltages even in the presence of nondestructive and little-magnitude over voltages [11-12]. These repetitive switches will lead to chatter in power switches, premature aging and reliability reduction. Using Hysteresis-Band in the control loop alleviates excessive switches. Hysteresis-Band was designed so that the output voltage error (overvoltage) settled in an acceptable range.

7. SIMULATION RESULTS

Surge protection designers usually select MOV's protection voltage level a little higher than the system's voltage. In the proposed method peak fundamental frequency voltage is detected using a Band Pass Filter. Therefore, surge voltage clipping can be better than conventional MOVs. The simulated system consists of a 50Hz voltage source, a 200km length transmission line and a lagging load (a parallel R-L circuit). The surge source is located in the middle of the line. Line parameters are listed in Table 3.

Table 3. Line parameters

Resistance	0.2568 ohm/km
Inductance	0.002 H/km
Capacitance	8.6 nF/km
Line model	π (10 sections)

Two criteria are analyzed to compare the proposed system and MOVs: standard lightning impulse and standard switching impulse. Simulations are performed for $t = 0.003$ sec. Results are presented in Figs. 8-13 in which horizontal axis is time in seconds and vertical axis is load voltage amplitude in per units (pu).

The MATLAB/SIMULINK software was used to simulate the proposed method and metal-oxide surge arrester behavior. In this software MOV is modeled as a highly nonlinear voltage-dependent resistor formulated as (1). Where: V_r is reference voltage, I_r is reference current and k_i and α_i are default parameters. As the Surge Arrester block is highly nonlinear, a stiff integrator algorithm was used to simulate the circuit. Ode15s or ode23tb (are of MATLAB numerical solvers) with default parameters usually give the best simulation speed. For continuous simulation, in order to avoid an algebraic loop, the voltage applied to the nonlinear resistance is filtered by a first-order filter with a time constant of 0.01 microseconds. This very fast time constant does not significantly affect the result accuracy. Model parameters were provided by the main metal-oxide arrester manufacturers. Thus, it has enough accuracy in power system transient modeling.

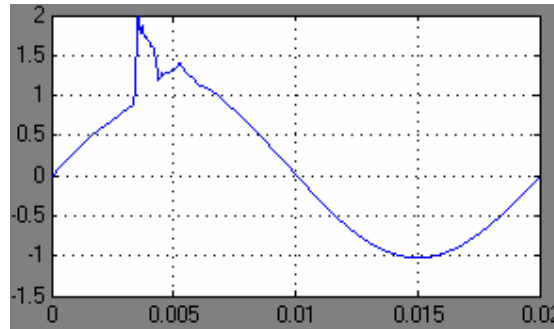

Fig. 8. Load voltage in presence of switching impulse without suppression

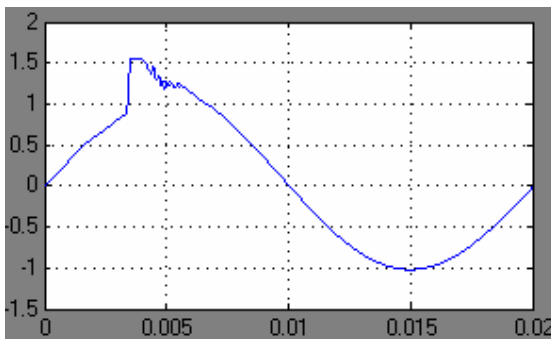

Fig. 9. Load voltage in presence of switching impulse and MOV

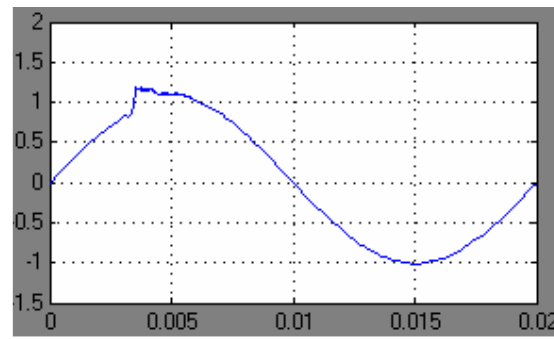

Fig. 10. Load voltage in presence of switching impulse and proposed suppression method

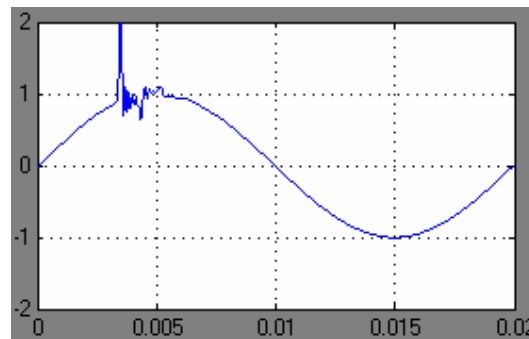

Fig. 11. Load voltage in presence of lightning impulse without suppression

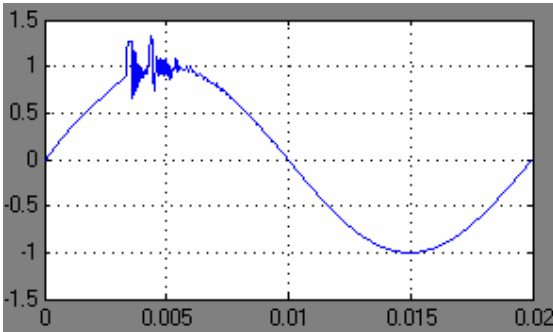

Fig. 12. Load voltage in presence of lightning impulse and MOV

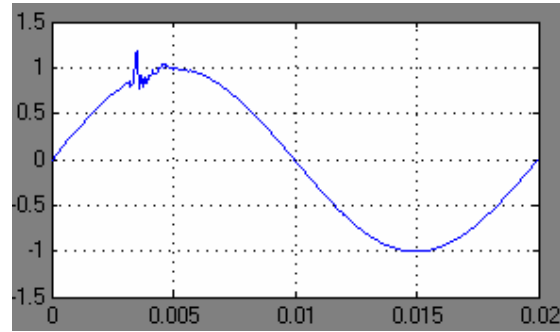

Fig. 13. Load voltage in presence of lightning impulse and proposed suppression method

8. CONCLUSION

In this study, a fuzzy hysteresis-band controlled variable resistor was introduced to suppress power system transient over-voltages. The proposed circuit has a relatively low response rate (in the presence of power electronic devices). However, simulation results show that the proposed system has reasonable performance under surge over-voltages because of predictive behavior provided by fuzzy control, especially in large duration surges. The proposed method used a sinusoidal reference voltage instead of constant reference (threshold) voltage; Figs. 9-10 and Figs. 12-13 represent the effectiveness of this selection. Also, simulations show that the proposed system can eliminate the major disadvantages of the MOVs and achieve the following advantages of the following:

- 1) Protection voltage can be selected close to system nominal voltage (because of sinusoidal reference voltage selection).
- 2) The resistor array can act as a multi-valued resistor instead of two-valued resistor.
- 3) The proposed circuit can reach a small slope resistor (by paralleling appropriate resistors).
- 4) Protection process depends both on the voltage amplitude and its derivative, thus the system becomes predictive.
- 5) The threshold voltage is optional and controllable.
- 6) The proposed circuit has negligible leakage current.

REFERENCES

1. Darveniza, M. (1991). Lightning protection of power systems. *JEEEA, IEAust and IREE*, Vol. 11, pp. 201-209 (Sir John Madsen Medal).
2. Standler, R. B. (1989). *Protection of electronic circuits from over voltages*. Wiley, (text for E3452 and E3417, refer App. II and III).
3. Darveniza, M. (1992). *Overvoltages, insulation selection and coordination*. Lect. B3 in Residential School in Electric Power Systems Engineering, University of Queensland, Vol. 1, pp. 509-538.
4. Mungkung, N., Wongcharoen, S., Tanitteerapan, T., Saejao, C. & Arunyasot D. (2007). Analysis of lightning surge condition effect on surge arrester in electrical power system by using ATP/EMTP program. *Proceedings of World Academy of Science, Engineering and Technology*, Vol. 22.
5. Nucci, C. A., Rachidi, F., Ianoz, M. V. & Mazzetti, C. (1993). Lightning-induced overvoltages and overhead lines. *IEEE Trans. Electromagn. Compat.*, Vol. 35, No. 1, pp. 75-86.
6. Fmehlich, K., Hoelzl, C., Carvalho, A. C. & Hofbauer, W. (1995). *Transmission line controlled switching*. Canadian Electrical Association, Vancouver.
7. Mendel, J. M. (1995). *Fuzzy logic systems for engineering: a tutorial*. *Proceedings of the IEEE*, Vol. 83, pp. 345-375.

8. Bose, B. K. (1990). An adaptive hysteresis-band current control technique of a voltage fed PWM inverter for machine drive system. *IEEE Transactions on Industrial Electronics*, Vol. 37, pp. 402-408.
9. Heno, H., Capolino, G. A. & Martinez-Velasco, J. A. (1996). A new structure of fuzzy- hysteresis current controller for vector controlled induction machine drives. *Proceedings of the IEEE Power Electronics Specialist Conference (PESC)*, pp. 708-712.
10. Gholami, A., Mirzaie, M. & Aseban, M. R. (2006). Theoretical and analytical investigation of lightning over-voltages and arrester operation. *Iranian Journal of Science & Technology, Transaction B, Engineering*, Vol. 30, No. B2.
11. Kazemi, A., Mousavi Badejani, S. M. & Masoum, M. A. S. (2006). Analysis and control of voltage harmonics generated by thyristor controlled series capacitors. *Iranian Journal of Science & Technology, Transaction B, Engineering*, Vol. 30, No. B2.
12. Gu, I. Y. H. & Bollen, M. H. J. (2000). Time-frequency and time-scale domain analysis of voltage disturbances. *IEEE Trans. Power Del.*, Vol. 15, No. 4, pp. 1279–1284.